

FT-SERIES CENTRIFUGAL BOWL FEEDER

**CLOCKWISE
or
COUNTER-CLOCKWISE
ROTATION**



MODELS:
FT-15
FT-20
FT-30
FT-40
FT-50

Model FT40 with
EP8 Prefeeder

FEATURES & BENEFITS:

- Simple design translates to an easy installation.
- Clean, logical control panel design makes the machine easy to operate.
- Custom tooling for your specific part yields a reliable and efficient operation.
- Dual motor drive system facilitates easy product changeover, resulting in less downtime and greater machine efficiency.
- Standard construction incorporates a design suitable for most pharmaceutical, food and industrial installations.
- Solid frame construction and quiet, energy efficient drive system provides years of high performance with low noise.
- Many options available, allowing the end user to customize the feeder to their specific needs.

FT-SERIES CENTRIFUGAL BOWL FEEDER

TYPICAL CENTRIFUGAL FEEDING SYSTEM

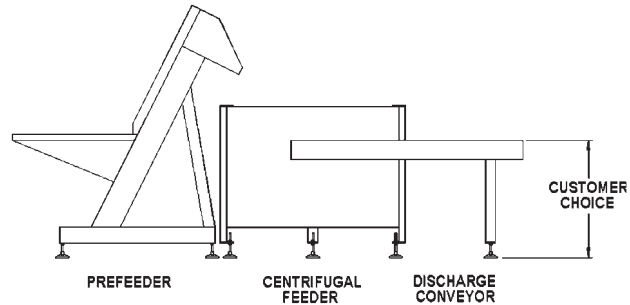

TYPICAL UTILITY REQUIREMENTS:

ELECTRICAL: 115 VAC 20 Amps Max,
Variable Speed DC Drives

AIR: 80 PSI (when required) Filler and
Regulator Provided

SPEED RANGE:

- Up to 1200 Parts Per Minute
- Typical range is 30 to 300 PPM
(depending on part characteristics)

OPTIONS AVAILABLE:

- Clockwise or Counterclockwise Rotation
- Multiple Part Tooling
- Stainless Steel, USDA/FDA Stainless Steel Washdown Construction
- Standard and Custom Bulk Storage Hoppers
- Discharge Conveyors
- Gravity Tracks
- Powered Orienting Gravity Rollers
- High Level Inhibit System
- Lexan Bowl and Hopper Covers
- AC Drive Motor
- ANSI or Metric Construction
- Escapements, Shuttles, Pick and Place, and Other Custom Out-of-Bowl Product Handling

PRODUCT SIZE RANGE:

- ¼" x ¼" to 4" x 6"

Interex
Est. 1976

TRADING & MARKETING

www.interex-usa.com

info@interex-usa.com